

Cassonata totale a parete . Wall total cassette awning

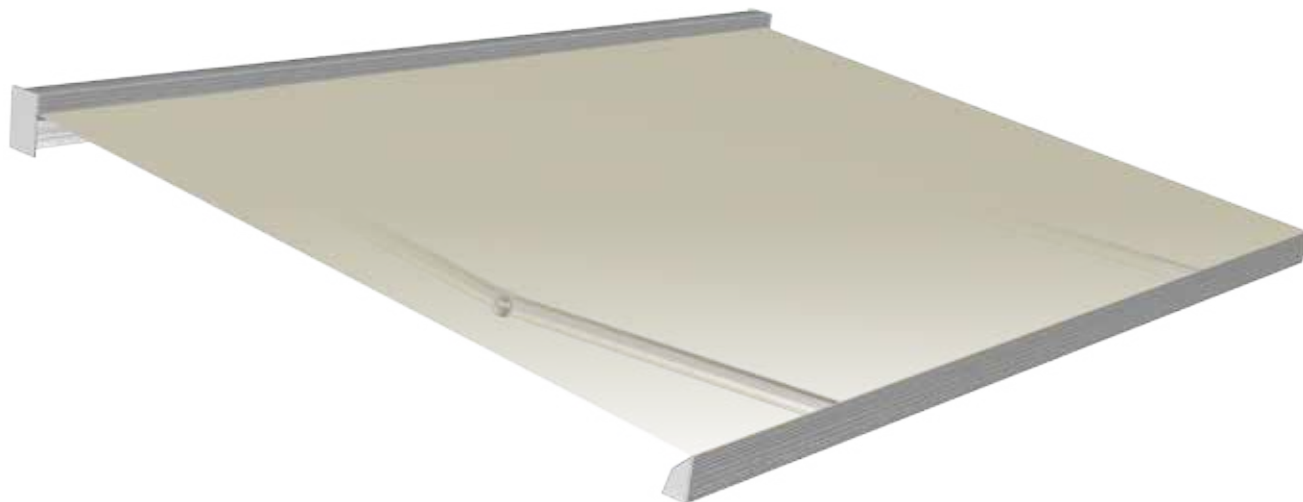

Tenda a cassetto, dal design depositato caratterizzato da effetto "pietra", con bracci a pantografo e luci integrate. La grande robustezza e le ridotte dimensioni sono le principali caratteristiche. Viteria esposta in acciaio inox ove possibile. Verniciatura con polveri poliestere eseguita presso il nostro stabilimento seguendo rigidi standard qualitativi. Regolazione micrometrica dell'inclinazione bracci. Funzionamento esclusivamente a motore. Campo di lavoro dei bracci da 5° a 45° dall'orizzontale. Sporgenza minima mt. 2.50, massima mt. 4.25. Larghezza massima mt. 8.00. Tenda confezionata preassemblata senza giunzioni.

Cassette awning, by registered design characterised by the "stone" effect, with aluminium arms and integrated lights. Great strength and reduced dimensions are its main characteristics. Where possible bolts and screws made of stainless steel. Painting by polyester powder in our factory performed following rigid qualitative standards. Micrometric regulation of the arms. Working by motor only. Working field of the arms from 5° to 45° at the horizontal. Minimum projection mt. 2.50, maximum mt. 4.25. Maximum width mt. 8.00. Packaged awning pre-assembled without joints.



Standard



59 colori struttura di serie
59 structure colours standard



Tessuti grandi altezza non consigliati.
Peso tessuto consigliato max 480 gr/mq.
Large width fabrics not recommended.
Weight recommended fabric max 480 gr/sqm.

Optional



No Opatex

Dati tecnici . Technical data



Classe 2

Attacco a parete . Wall application

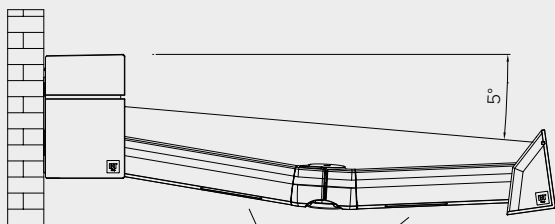

Braccio brevettato con sistema luci integrato
Patented arm with integrating lighting system

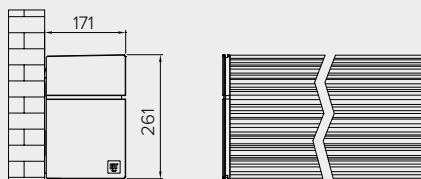
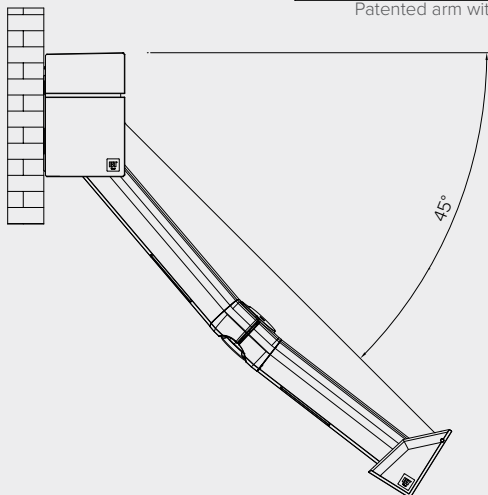

Luci LED integrate nel profilo cassonetto
Led lights integrated into the casing profile

Carter centraline/alimentatori 095-910
Carter control unit/power supply

